



2 Conferences - 1 Location



**9th EOOSC European Oxygen
Steelmaking Conference**



**6th CTSI Clean Technologies
in the Steel Industry**

First Announcement

October, 17 – 21, 2022
Aachen – Germany
www.EOOSC-CTSI.com



Steel Institute
VDEh

2 CONFERENCES - 1 LOCATION

The joint conferences are aimed at creating an opportunity for a technical exchange at an international level among the numerous experts involved in the steelmaking to inform on the latest technical achievements in all production phases and the environmental benefits of steel utilization.

9TH EOSC

The European Oxygen Steelmaking Conference (EOSC) series is organised in turn by one of the European Metallurgical Societies and Associations. As such it represents the most comprehensive expert knowledge in steelmaking. The Conference will present the state of the art technologies and developments and discuss technology issues related to the specific requirements of oxygen steelmaking.

6TH CTSI CLEAN TECH

6th CTSI European Conference on Clean Technologies in the Steel Industry will provide a forum for researchers and steel manufacturers to review recent developments in environmental protection and efficiency in steelmaking focussing on environmental and energy aspects in iron and steelmaking.

WHAT TO EXPECT:

Both events will provide a forum for best practise and state of the art technology, new developments, new ideas and research results.

About 700 experts are expected to attend. An extended exhibition area will bring together key players from above mentioned expert fields.

This meeting is aimed at creating an opportunity for a technical exchange at an international level among the numerous experts involved in the steelmaking to inform on the latest technical achievements in all production phases and the environmental benefits of steel utilization. We kindly invite you to participate in 9th EOSC + 6th CTSI CLEAN TECH and are looking forward to meeting you in Aachen in 2022!

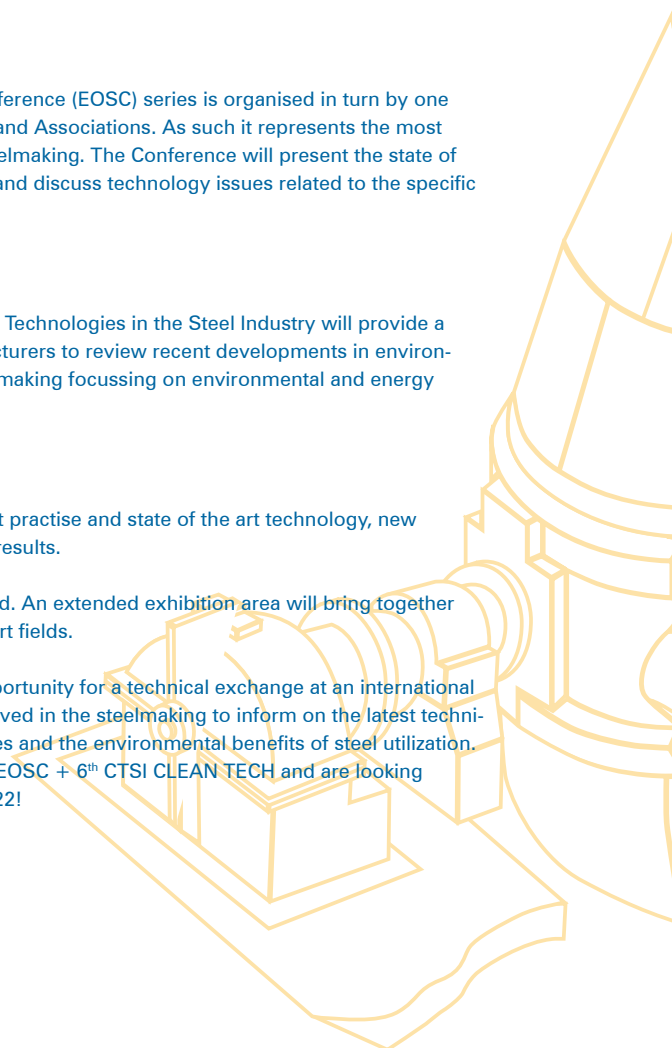

PLATINUM SPONSOR

19,500 EUR

(MAIN SPONSOR)

ON SITE:

- 18 sqm booth area, preferential position in the exhibition area, booth construction is not included
- Highlighted company display during breaks
- Includes full registration for 10 attendees

WEBSITE:

- Exclusive position with link on EOSC-CTSI website
- Preferential company presentation and mention as Platinum Sponsor on EOSC-CTSI website
- Integration of a corporate image film on EOSC-CTSI website

PRINT:

- Logo placement on lectern in all rooms
- Logo placement in flyers, newsletters and posters
- Logo presentation on the welcome banner in the foyer
- Admission into the program committee
- 2 custom made roll-ups (which remain your property after the conference)
- Company banner and mention as Platinum Sponsor on EOSC-CTSI sponsor roll-ups
- Full page advertisement in the program folder
- Highlighted advertisement in the digital conference proceedings
- Logo and short portrait on digital conference proceedings
- Logo placement on label of digital conference proceedings
- Presentation of own materials on digital conference proceedings (up to 50 MB)
- Logo imprinted on conference bags
- Materials included in the conference bags (up to 2 items + 1 brochure)
- Mention in all press releases



GOLD SPONSOR

12,500 EUR

ON SITE:

- 12 sqm booth area, preferential position in the exhibition area, booth construction is not included
- Includes full registration for 6 attendees

WEBSITE:

- Listing with link on EOSC-CTSI website
- Company presentation and mention as Gold Sponsor on EOSC-CTSI website

PRINT:

- Logo placement in flyers, newsletters and posters
- Logo presentation on the welcome banner in the foyer
- Company logo on EOSC-CTSI sponsor roll-ups
- Half page advertisement in the program folder
- Advertisement in the digital conference proceedings
- Presentation of own materials on digital conference proceedings (up to 30 MB)
- Material included in the conference bags (1 item)
- Mention in press releases

SILVER SPONSOR

7,500 EUR

ON SITE:

- 8 sqm booth area, booth construction is not included
- Includes full registration for 4 attendees

WEBSITE:

- Listing with link on EOSC-CTSI website
- Company presentation on EOSC-CTSI website

PRINT:

- Logo placement in flyers, newsletters and posters
- Company logo and mention as Silver Sponsor on EOSC-CTSI sponsor roll-ups
- Presentation of own materials on digital conference proceedings (up to 20 MB)
- Material included in the conference bags (1 item)



EXHIBITOR PACKAGE "BOOTH"

4,500 EUR

- 8 sqm floor space (2 x 4 m)
- Fully equipped with booth (Standard exhibition construction, electricity, carpet, table, 2 chairs, 1 rack for brochures, 1 triple-socket)
- Includes full registration for 1 attendee

EXHIBITOR PACKAGE "SPACE"

2,500 EUR

- 6 sqm floor space (2 x 3 m)
- No booth construction included
- Includes full registration for 1 attendee

ADDITIONAL EQUIPMENT, FURNITURE

A basic booth construction and lighting is mandatory to ensure an appealing presentation of the exhibition.

Customized booth layouts or additional items are possible but will usually result in additional costs. Please do not hesitate to contact us, should you have any special requests. We will do our utmost to meet your individual requirements.

The maximum booth height depends on the position of your stand. Please contact TEMA for additional information.

German VAT will be added to all prices.



ITEM SPONSORS

Contact us to discuss individually how you can be presented best at 9th EOSC and 6th CTSI.

PROCEEDINGS :

- Secure your logo on the proceedings to be handed out to all participants

3,200 EURO

ADVERTISEMENT IN PROGRAM :

- 1/1:
- 1/2:

980 EURO
490 EURO

LOGO ON CONFERENCE BAGS :

- Each participant receives a conference bag at their arrival at the conference, Sponsor's logo printed on all conference bags

2,000 EURO

PENS :

- Your pens distributed to all participants

1,500 EURO

NOTEPADS :

- Sponsor's name, logo and website are printed on the notepads

3,500 EURO

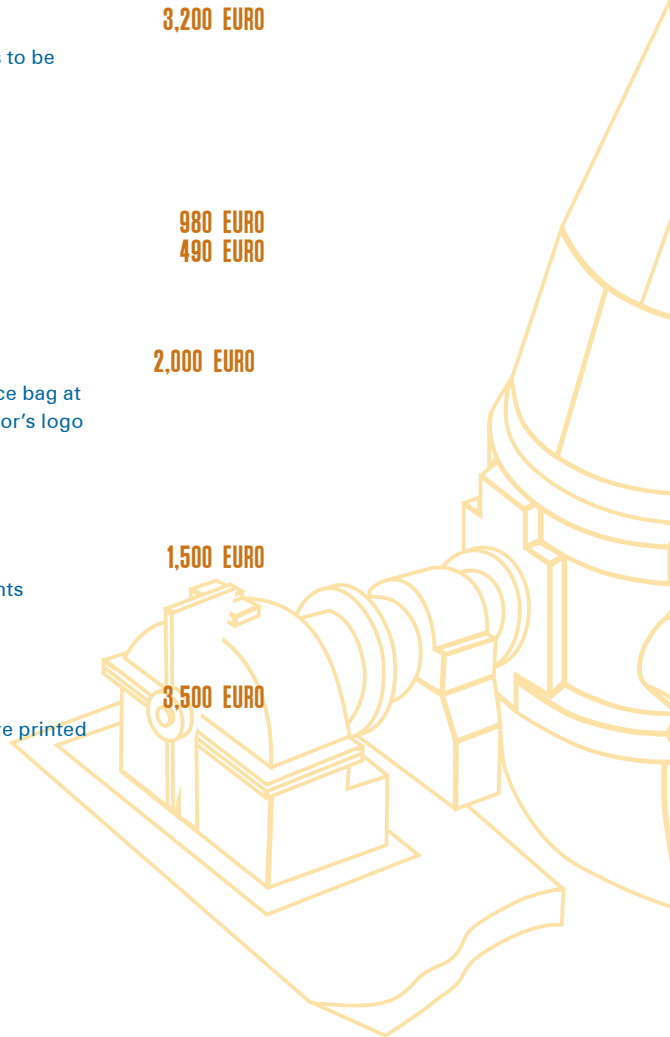

REGISTRATION FORM FOR SPONSORING OR EXHIBITING AT THE "EOSC-CTSI CONFERENCE & EXHIBITION"

Please fax back to: +49 (0)241 88970 999, attn. Mr. Carsten Scheele
or send via email to info@eosc-ctsi.com

I would like to sponsor/exhibit at the EOSC-CTSI, October, 17 – 21, 2022, Aachen – Germany

Company/ Institute

Contact Person

Address

Zip Code

City

Country

Phone

Fax

E-mail

Please mark with a cross the package you want to book

SPONSORING PACKAGES

EXHIBITING PACKAGES

- | | | | |
|---|------------|--|-----------|
| <input type="radio"/> Platinum Sponsor: | 19,500 EUR | <input type="radio"/> Exhibitor Package "Booth": | 4,500 EUR |
| <input type="radio"/> Gold Sponsor: | 12,500 EUR | <input type="radio"/> Exhibitor Package "Space": | 2,500 EUR |
| <input type="radio"/> Silver Sponsor: | 7,500 EUR | <input type="radio"/> Item Sponsor: | |

..... Sponsor for EUR

Additionally: entry tickets (650 EUR per ticket) EUR

I understand that the organizer reserves the right to cancel and/or modify the above-mentioned event and/or services offered at any time.

Date/legally binding signature

SPONSORING PACKAGES	PLATINUM	GOLD	SILVER
Booth area	18qm	12qm	8qm
Highlighted company display during breaks	x	-	-
Free voucher	10	6	4
Website:			
Listing with link	Preferential	x	x
Company presentation	Preferential	x	x
Integration of a corporate image film	x	-	-
Print:			
Logo placement on lectern in all rooms	x	-	-
Logo placement in flyers, newsletters and posters	x	x	x
Logo presentation on the welcome banner in the foyer	x	x	-
Admission into the program committee	x	-	-
2 custom made roll-ups	x	-	-
EOSC-CTSI sponsor roll-up	Company banner	Logo	Logo
Advertisement in the program folder	Full page	Half page	-
Logo and short portrait on digital conference proceedings	x	-	-
Logo placement on label of digital conference proceedings	x	-	-
Presentation of own materials on digital conference proceedings	50MB	30MB	20MB
Logo imprinted on conference bags	x	-	-
Materials included in the conference bags	2 items + 1 brochure	1 item	1 item
Press releases	x	x	-
Costs	19,500 EUR	9,500 EUR	7,500 EUR

German VAT will be added to all prices.



HOST

Steel Institute VDEh
 Dr.-Ing. Hans Bodo Lüngen
 Sohnstr. 65 | 40237 Düsseldorf
 Germany
 Phone: +49 211 6707-444
 Telefax: +49 211 6707-440
www.vdeh.de

ORGANIZATION / CONGRESS SECRETARIAT

TEMA Technologie Marketing AG
 Mr. Carsten Scheele
 Aachener-und-Münchener-Alle 9
 52047 Aachen | Germany
 Phone: +49 241 88970-300
 Fax: +49 241 88970-999
 Email: info@eosc-ctsi.com | www.tema.de

